

Additional water in

Equipment List

- RE-1 Infeed hopper, lid and screw conveyor
- RE-2 Primary crusher (coarse) <25mm
- RE-3 Pump
- RE-4 Metal detector and divert valve
- RE-5 Roller Mill
- RE-6 Screw conveyor
- RE-7 Rotacut <8mm
- RE-8 Transfer pump and hopper
- HE-1 Buffer tank stirrer
- HE-2 Primary feed pump
- HE-3 Primary Kettle
- HE-4 Cooker
- HE-5 Cooker stirrer
- HE-6 Recirc pump
- HE-7 Recirc kettle
- HE-8 Feed pump – decanter 1
- HE-9 Feed pump – decanter 2
- HE-10 Steam strainer
- HE-11 Steam pressure reducer
- HE-12 Over-pressure switch
- SE-1 Decanter centrifuge 1
- SE-2 Decanter centrifuge 2
- SE-3 Centrate pump
- SE-4 Solids removal conveyor
- SE-5 Solids transport conveyor
- CE-1 Electrical generator
- CE-2 Waste heat boiler
- CE-3 Air condenser

Instrument List

- HI-1 Buffer tank level
- HI-2 Primary feed coriolis meter
- HI-3 Primary kettle temp sensor
- HI-4 Cooker temp tensor
- HI-5 Process temp sensor
- HI-6 Decanter feed tanks level sensor
- SI-1 Oil tank level sensor
- SI-2 Centrate water level sensor
- V-0 Manual isolation valves
- HV-1 3 port L-flow actuated process valve
- HV-2 3 port L-flow actuated recirc valve
- HV-3 Primary kettle steam control valve
- HV-4 Recirc kettle steam control valve
- HV-5 Primary kettle steam shutoff valve
- HV-6 Recirc kettle steam shutoff valve
- SV-1 3 port L-flow actuated oil valve
- SV-2 3 port L-flow actuated oil valve
- CV-1 Engine exhaust divert valve

Tank List

- HT-1 Buffer tank
- HT-2 Decanter feed tank
- ST-1 Oil buffer tank (trace heated)
- ST-2 Waste water buffer tank

Pipe List

- Raw material
- Process water
- Dryer fume line
- Process
- Oil - Trace heated
- Steam

COMBINED HEAT AND POWER

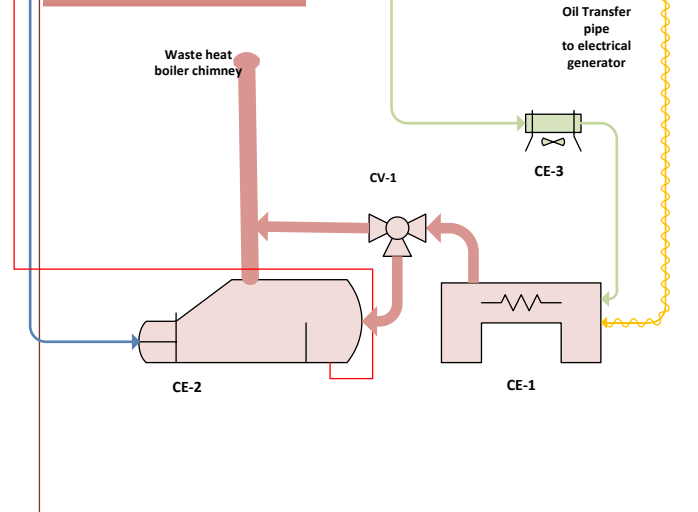

Agritec Systems Ltd
C502 plant – Edge view green energy
 December 2016
 Process flow and
 Main component schedule